

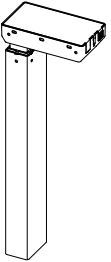







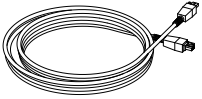
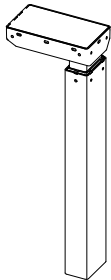

Assembly & Installation Instructions:

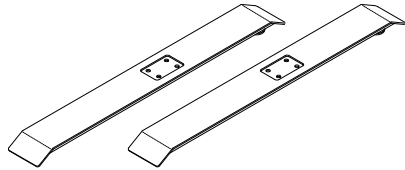
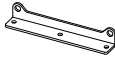
Fundamentals 2-Leg Workcenter FDEX30-48-X / FDLX30-48-X

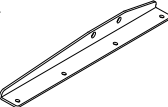
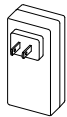
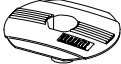
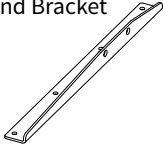
Parts Included

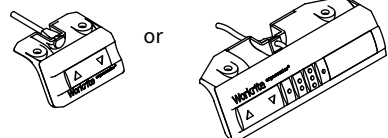
<p>A Master Leg Qty: 1</p> 	<p>G #M6 × 14 mm Flat Head Cap Screw Qty: 20</p> 	<p>O Power Cable - 3.5 meters Qty: 1</p> 
<p>B Companion Leg Qty: 1</p> 	<p>H Foot Glide Qty: 4</p> 	<p>P Feet Qty: 2</p> 
<p>C Short Bracket Qty: 4</p> 	<p>I #12 × 3/4" Pan Head Laminate Top Screw Qty: 21</p> 	<p>Q Standard or Programmable Switch Qty: 1</p>
<p>D Left End Bracket Qty: 1</p> 	<p>J Power Supply Qty: 1</p> 	<p>K Cable Spool Qty: 1</p> 
<p>E Right End Bracket Qty: 1</p> 	<p>L #8 × 5/8" Pan Head Screw Qty: 7</p> 	<p>or</p> 
<p>F 4 mm Allen Wrench Qty: 1</p> 	<p>M 3/16" Cable Loops Qty: 5</p> 	<p>Sold Separately: Worksurface</p>
	<p>N Leg Cable - 1 meter Qty: 1</p> 	

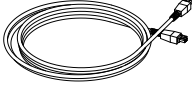
⚠ WARNING: Maximum loading of table assembly is 125 lb. (56.7 kg.). Maximum load includes the weight of the table top itself, any equipment placed upon it, and any equipment suspended or hanging under it. Loading should be evenly distributed over table surfaces. “Payload Capacity” is the Workrite Ergonomics recommended maximum loading which includes the Workrite sourced table top.

Fundamentals 2-leg

V = 120VAC, 60Hz / 2.5 A maximum

IMPORTANT SAFETY INSTRUCTIONS:

When using an electrical furnishing, basic precautions should always be followed, including the following:
Read all instructions before using this Fundamentals Workcenter.

DANGER: To reduce the risk of electric shock, always unplug this Fundamentals Workcenter from the electrical outlet before cleaning.

⚠ WARNING: To reduce the risk of burns, fire, electric shock, or injury to persons:

1. Unplug from outlet before putting on or taking off parts.
2. Close supervision is necessary when this furnishing is used by, or near children, invalids, or disabled persons.
3. Use this furnishing only for its intended use as described in these instructions. Do not use attachments not recommended by the manufacturer.
4. Never operate this furnishing if it has a damaged cord or plug, if it is not working properly, if it has been dropped or damaged, or dropped into water. Return the furnishing to a service center for examination and repair.
5. Keep the cord away from heated surfaces.
6. Do not use outdoors.
7. Do not operate where aerosol (spray) products are being used or where oxygen is being administered.
8. To disconnect, remove plug from outlet.
9. Each surface intended to support an equipment payload capacity of 125 pounds.

FOR COMMERCIAL USE ONLY

SAVE THESE INSTRUCTIONS



IMPORTANT NOTE!

You must complete initialization (Step 10) at the end of assembly or your workcenter WILL NOT FUNCTION PROPERLY.

✓ Verify that you have all the tools needed for the assembly

You will need the following tools:

- #2 tip Phillips screwdriver or drill/driver
- #3 tip Phillips screwdriver or drill/driver
- M4 tip bit or 4 mm Allen Wrench (E)

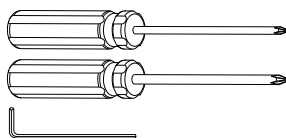

or

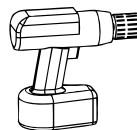

If you do not have a Workrite worksurface, you will also need:

- 1/8" pilot drill bit
- 3/32" pilot drill bit



1 Attach Short & Medium Brackets

1.1 Attach Short Brackets (C) using Allen Wrench (F) and Flat Cap Screws (G) to both legs. **Do not tighten screws completely.**

1.2 Attach Right End Bracket (E) to sides of the right (Master) Leg (A) using Flat Cap Screws (G). Attach Left End Bracket (D) to sides of the left (Companion) Leg (B) using Allen Wrench (F) and Flat Cap Screws (G) and tighten securely.



To avoid stripping the threads, always insert and make the first few turns of the screw **BY HAND** with an Allen wrench (F), ensuring it is in straight.

Note: the right leg will be on your left and vice versa when the assembly is seen upside down.

Hardware at actual size

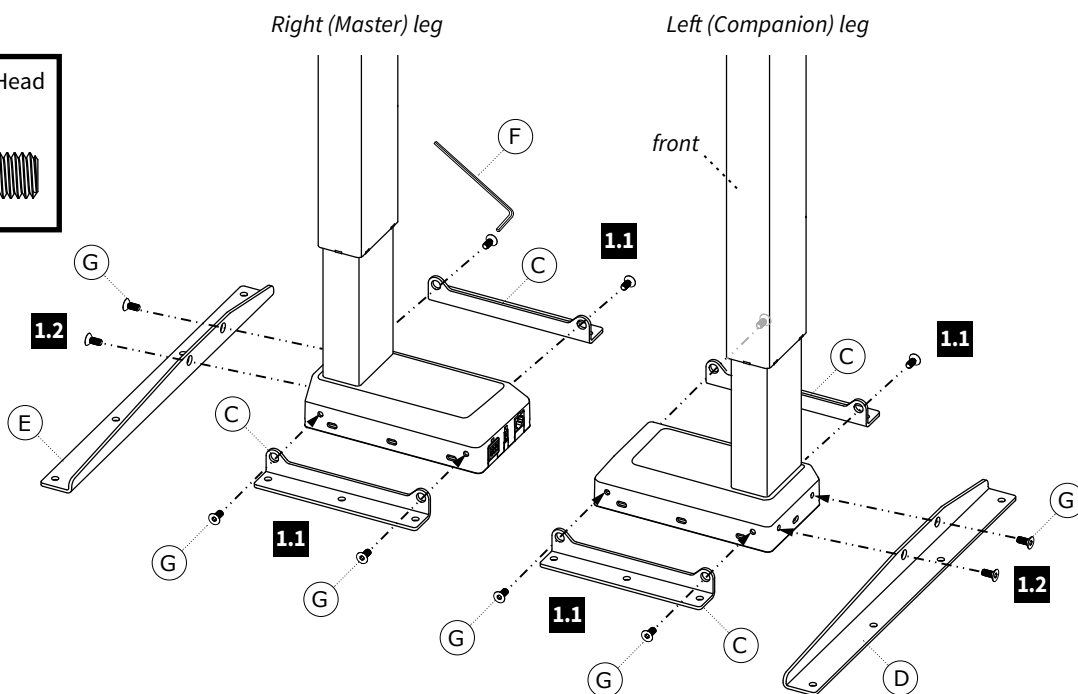
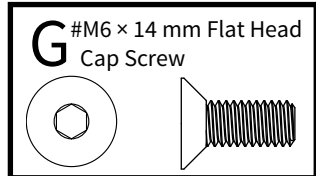

2 Pre-drilled Worksurface

Note: For **Workrite Top**, position leg assembly to align mounting holes in brackets to pre-drilled holes in worksurface.

For **Non-Workrite Top**, follow steps below.

2.1 Position leg assemblies on bottom side of worksurface $6\frac{1}{8}$ " from front of top and $2\frac{7}{8}$ " from side as shown in illustrations.

2.2 Mark placement of mounting holes, then use $\frac{1}{8}$ " drill bit to drill pilot holes at marked locations. You may wish to mark your drill bit so you do not drill any more than $\frac{3}{4}$ " deep and damage your worksurface top.

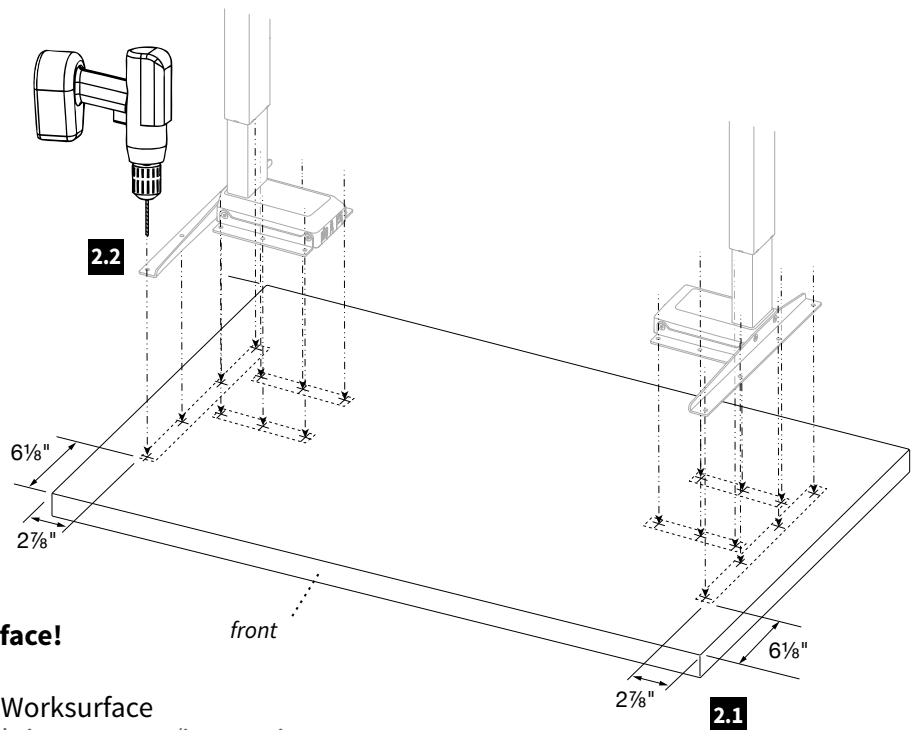

Do not drill all the way through worksurface!

Note: For 2-Leg Equal Corner and 120° Worksurface Mounting Instructions, go to: www.workriteergo.com/instructions

3 Attach Base to the drilled Worksurface

3.1 Install four (4) #12 × $\frac{3}{4}$ " Pan Head Laminate Top Screw (I) in corners. Leave loose for next step.

3.2 Install remaining #12 × $\frac{3}{4}$ " Pan Head Laminate Top Screw (I) and tighten securely. If you use electric screwdriver, be sure it is on the lowest torque setting to avoid stripping the holes on top.

3.3 Tighten first four (4) screws securely.

Do not drill all the way through worksurface!

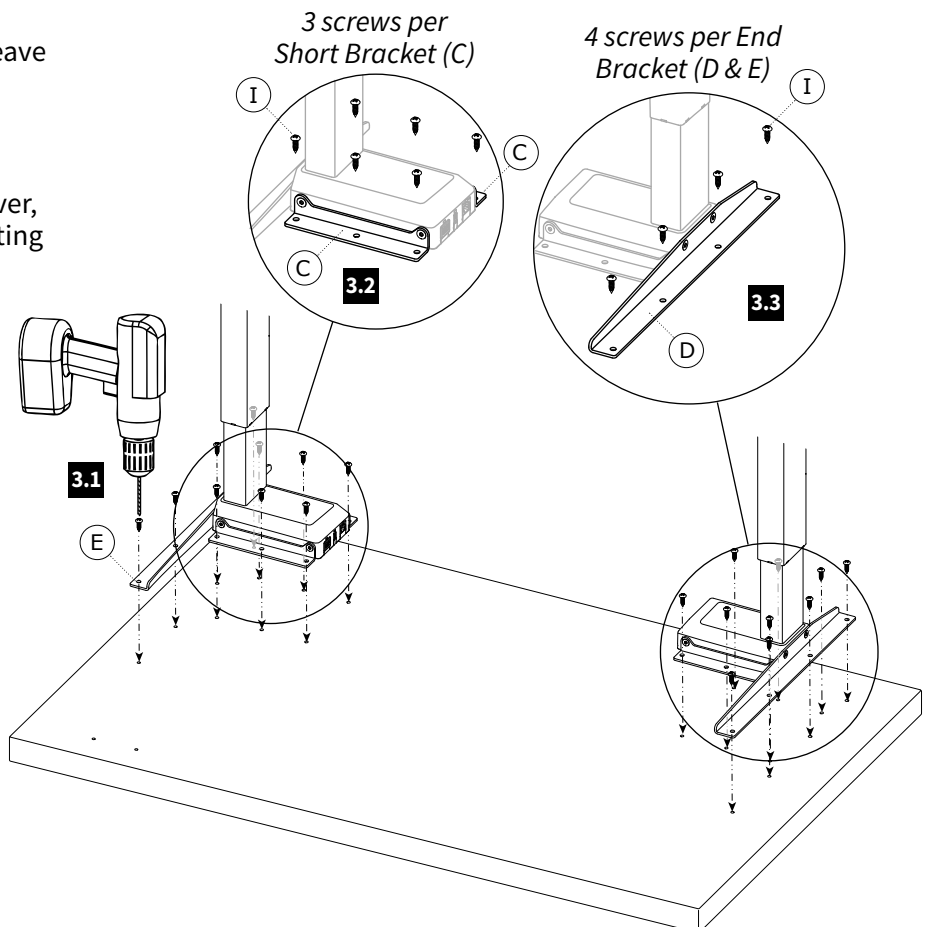

Hardware at actual size

#12 × $\frac{3}{4}$ " Pan Head Laminate Top Screw

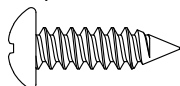

4 Attach Feet & Install Foot Glides

- 4.1 Install Feet (P) using #M6 × 14 mm Flat Head Cap Screws (G) included with this Frame Set.
- 4.2 Attach Foot Glides (H) to bottom of the Feet supplied in your Foot Kit.

Hardware at actual size

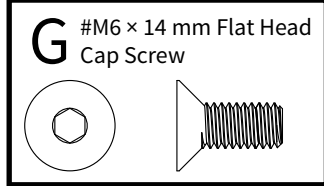

Be sure the longer end of the foot goes towards the front of the workcenter.

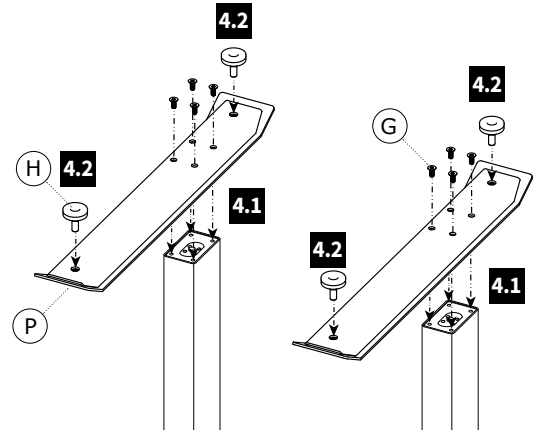

Caution!

Only use the #M6 × 14 mm Flat Head Cap Screw (G) for assembly.

5 Attach Switch

Install your switch (Q) using two #8 × 5/8" Pan Head Screws (L).

Hardware at actual size

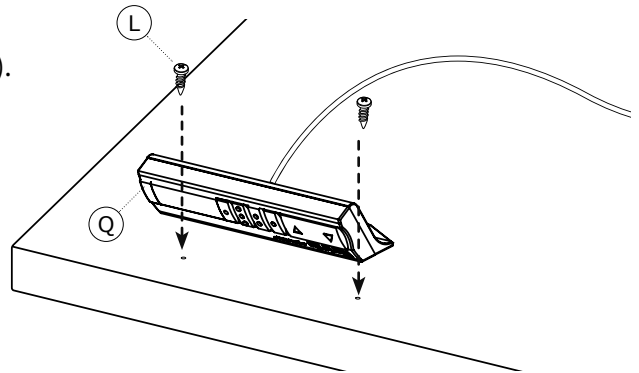
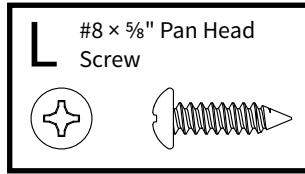

6 Attach Cable Spools and Cable Loops

- 6.1 Attach Cable Spool (K) with the #12 × 3/4" Pan Head Laminate Top Screw (I) to underside of worksurface.
- 6.2 Attach Cable Loops (M) to underside of worksurface using the #8 × 5/8" Pan Head Screw (L) making sure to wrap the Cable Loop around the cable prior to attaching.

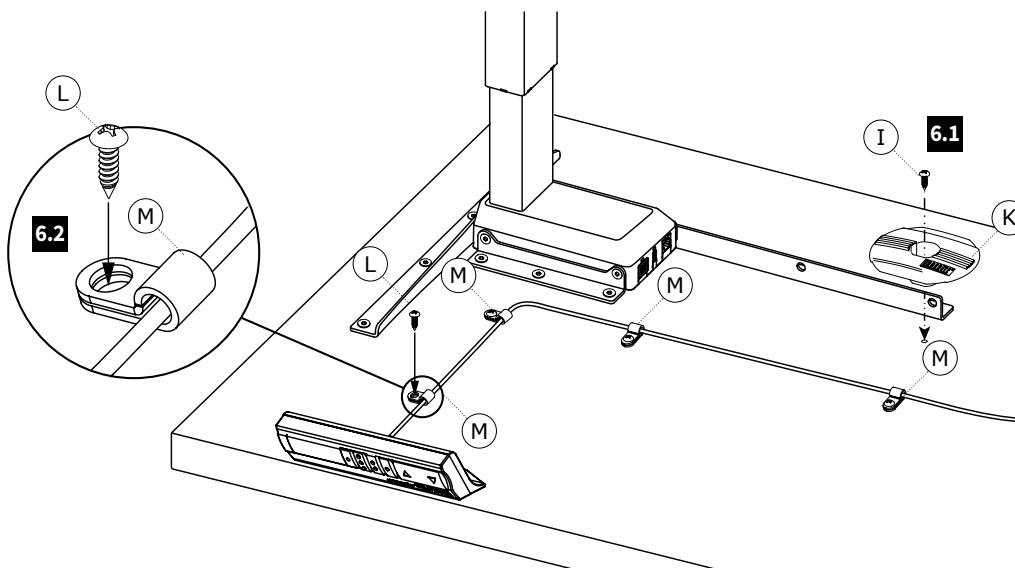

7 Connect Leg Cables to Master leg and Companion Leg

- 7.1 Connect the Leg Cable (N) to the six position connector labeled “1” on both the Master Leg and the Companion Leg (B).
- 7.2 Insert the Power Cable (O) into the two position connector labeled “DC” on the Master Leg.
- 7.3 Insert the Control Cable into the data connector labeled “A1” on the Master Leg.

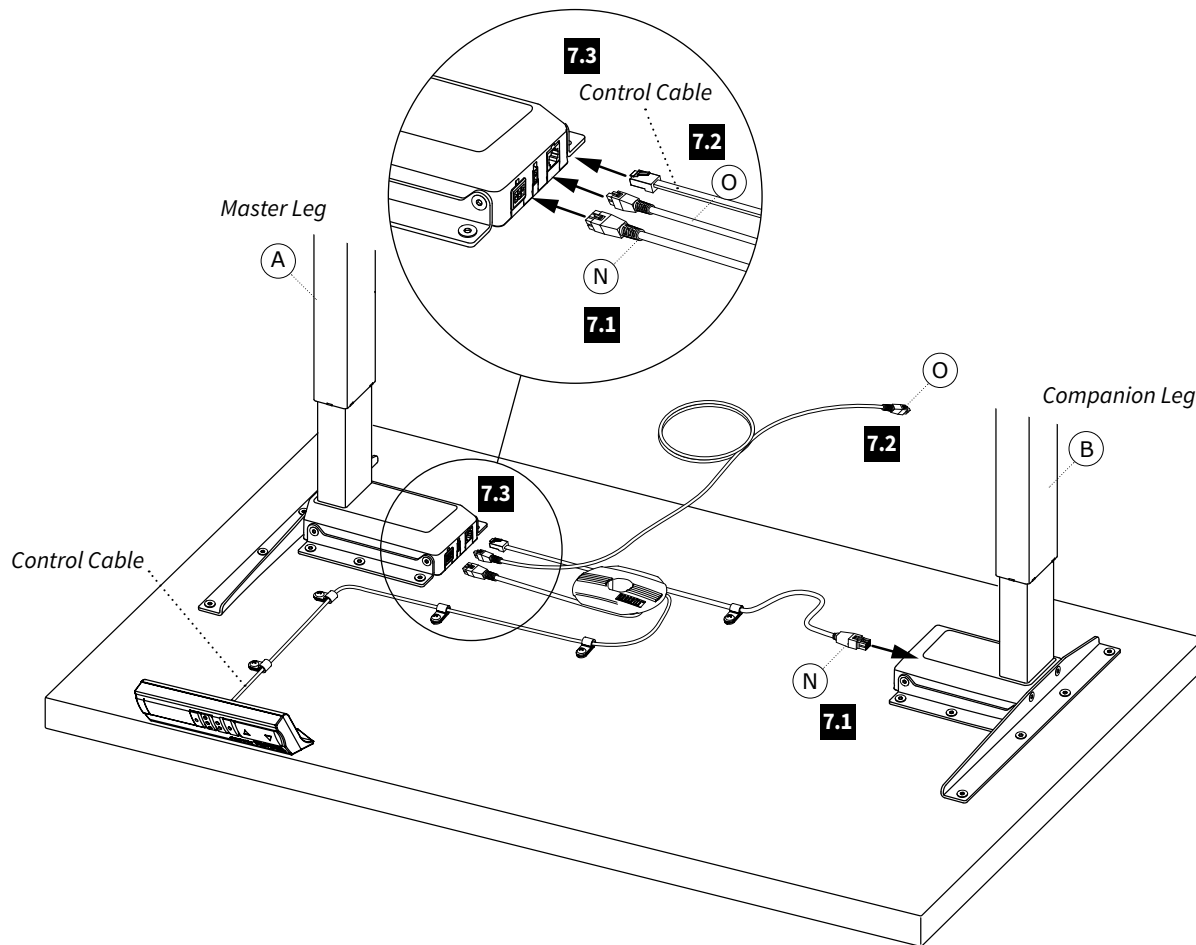

8 Connect Power Cable to the Power Supply and put workcenter upright

- 8.1 Connect the Power Cable (O) to the Power Supply (J).
- 8.2 Turn the table over into an upright position.
- 8.3 Plug the Power Cord into the power outlet.

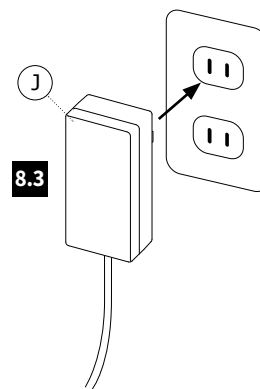
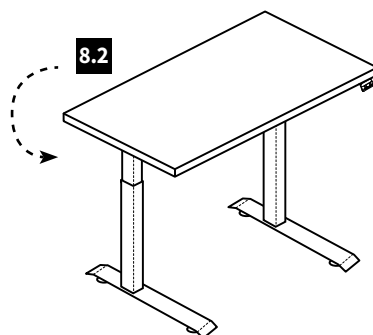
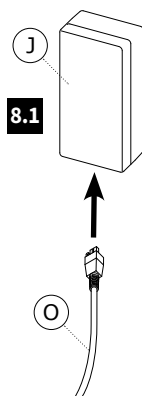

9 Adjust Feet Guides

If necessary, adjust leveling guides on table feet to level the worksurface. Unscrew to increase height, screw in to decrease height.

10 Initialize Legs

After all legs and the control are connected, and the power cord has been plugged in, hold the **down arrow** on the control until the legs make a short motion down and then back up. This initializes and synchronizes the table legs.

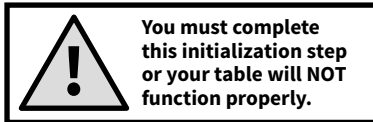

Hold down the down arrow until table moves slightly upwards

11 Set Control Switch Initial Settings (FDLX30-48-X only)

- 11.1** Press the DOWN button to move table to its lowest position.
- 11.2** If using a worksurface other than a Workrite top, measure height of table from floor to top of worksurface. If using a Workrite worksurface, the number to use will be 27.5".
- 11.3** Press and hold both the UP and DOWN buttons simultaneously. Three dashes will appear. Wait for the numeric display to return.
- 11.4** Press the UP button until the display reads 27.5" (for Workrite worksurfaces) or measured height (for others).
- 11.5** The display will flash when the change has been saved.

✓ Cleaning instructions

To clean the legs, apply cleaner to a soft cloth.

Suggested cleaners: Windex or Formula 409.

Do not use solvents and do not saturate or spray cleaners directly to table base.